



ECO-VALVES

Ecological Draining Solutions

Separation Valve

Type: T00





Model: TOO

Automatic Separation Valve

The ECO model TOO is a specific gravity sensitive valve, for automatic draining and separation of a heavier fluid from a lighter fluid.

Commonly used for draining of water accumulated in the bottom of petroleum product storage tanks where the stored medium has a lower specific gravity than that of the accumulated water. The TOO valve should be opened to initiate dewatering. When all the accumulated water has drained from the storage tank, the presence of the product is sensed by the TOO valve which automatically and immediately shuts off drip tight.

When fitted with the optional factory limit switch, a signal is sent to a remote valve position monitoring system, signaling that the valve is closed.

It is well suited for use with storage tanks containing Gasoline, Gas Oil, Jet Fuel, Kerosene and Diesel Oil. The TOO uses a simple and reliable principle with a straightforward and compact construction, designed to require minimal maintenance, and to last the lifetime of the tank.

Using TOO saves product loss, technician's health, reduced labor, tank maintenance and increases available tank storage space. It is environmentally cleaner, safer, more reliable and more efficient compared to manual or other methods. Each valve is assembled and tested in ECO's ISO 9001 certified manufacturing plant.

Introduced to the industry 25 years ago, the TOO is a time proven product used in the largest oil companies worldwide and backed by the Global Service Network of ECO - VALVES LTD.



Features and Benefits

Safety

- Reduces technician's exposure to harmful fumes
- Eliminates product spillage during dewatering.
- Includes built-in integral strainer for reliable sealing

High Performance

- Immediate closing response when product is detected
- High accuracy/repeatability
- High drain flow efficiency
- Built-in Anti Vortex Device for efficient controlled flow

Cost Effective

- Very low maintenance
- No external power supply needed
- Increases available product storage space
- Saves Labour
- Greatly reduces the plant's total water treatment volume

Factory Fitted Options

- Manual/Electrical/Pneumatic Pump for closed system & Green Solution
- Oil/Water Visual/Electrical Indicator
- Visual Valve Position Indicator

Cover

Vent/Sampling Valve

Inlet

Float Guide/Strainer

Float

Equalizing Valve

Seal

Outlet Valve

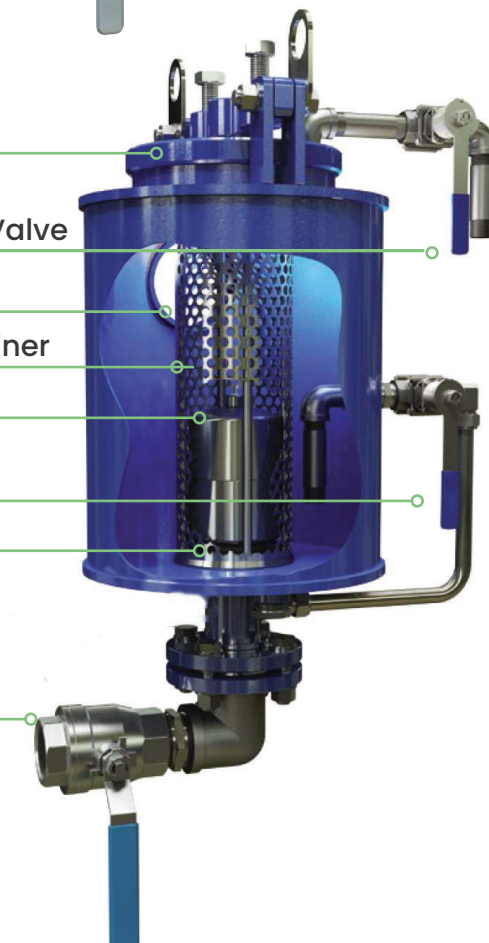



Principle of Operation

Normal Operation (Before Dewatering)

Water accumulated in the bottom of the storage tank reaches the TOO valve. At this stage the float (2) is pressed by the water pressure above it, against the seal at bottom of the valve sealing drip tight.

- (1) Equalizing Valve
- (2) Float
- (3) Seal
- (4) Outlet Valve

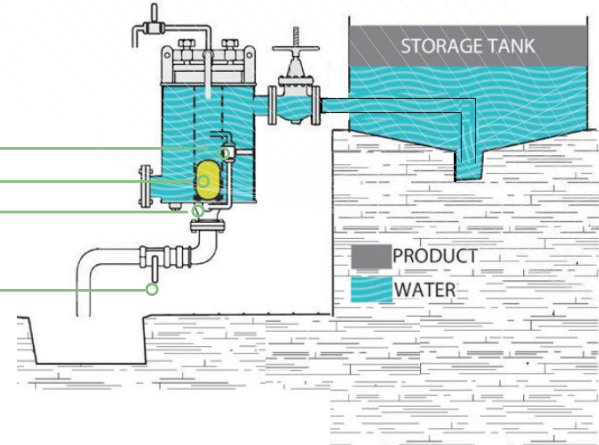

Dewatering

Dewatering is initiated by momentarily opening the pressure equalizing valve (1). If water is present, the float will rise thus opening the outlet seal (3). The outlet valve (4) should now be opened to allow free flow of the accumulated water to the drainage system. During drainage the Integral Strainer will help to keep the TOO seal clear of the debris often builds-up at the bottom of storage tanks, ensuring a reliable seal at the end of the dewatering session.

The built-in Anti Vortex Device will control the flow, preventing the formation of a Vortex within the storage tank, mixing the natural phase between the product and the collected water

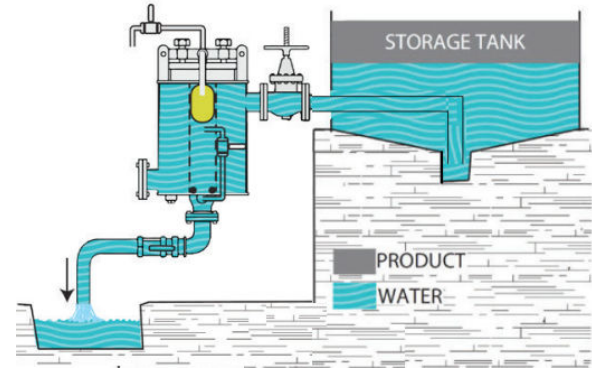

Normal Operation

When the water has completely drained and product enters the TOO valve, the float (2) quickly descends in the lighter medium and seals the valve.

After closing, the float remains hydraulically pressed against the seat, sealing the outlet. The TOO should be reset by closing the outlet valve (4) until the next dewatering session. Remaining product in the TOO will "float" back to the tank

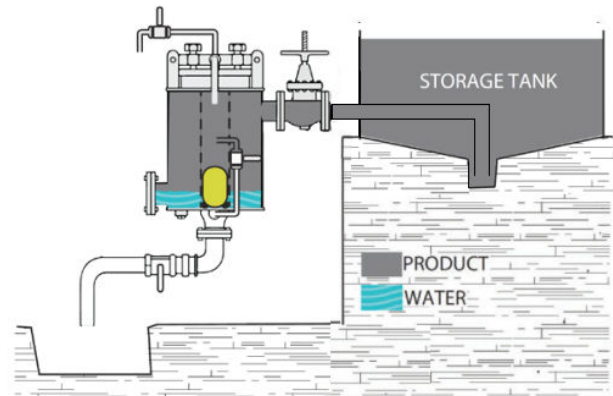

System P&ID

- | | |
|---|-------------------------------------|
| 1. Separating valve body | 6. Outlet ball valve |
| 2. Strainer/float guide | 7. Venting/sampling valve |
| 3. Balanced float | 8. Storage tank drain valve |
| 4. Vortex inhibitor | 9. Storage tank /gravity separation |
| 5. Equalizing valve (spring return N.C) | 10. Sump plug |

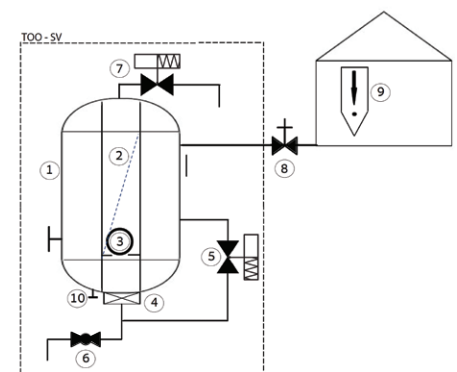



Typical Installation and Maintenance

In installation where there is not enough space from the ground using an elevation spool is recommended (see Fig 1-9). To enable the vortex inhibitor to perform correctly and prevent the formation of a vortex spout within the storage tank, there should be an air gap between the outlet and the drain (see Fig 1). This air gap serves as a suction breaker, and keeps the outlet flow stable. The flow or outlet capacity of the TOO is also determined by the inlet head before the TOO valve - see the Flow Chart on page 5.

In order to save the "oil dead leg" and to save the environment, a factory fitted manual/electrical/pneumatic pump is available to return (in a clean and efficient manner), any residual product left inside the TOO valve after dewatering, back to the tank or into a collecting vessel (see Fig 2).

The compact and lightweight construction of the TOO facilitates a trouble-free attachment of the device, usually directly onto existing outlet pipes or flanges. Opening the ECO TOO valve for periodical maintenance and access to all internal parts is accomplished by simply removing the fast releasing cover. The ECO TOO is designed for easy upkeep. It is lightweight and compact, yet has a robust construction with only one moving part and with all internal parts being manufactured in appropriate grade stainless steel.

1. Drain Valve
2. Vent/Sampling Valve
3. Equalizing Valve
4. Outlet Valve
5. Storage Tank
6. Elevation spool
7. Product Return Pump

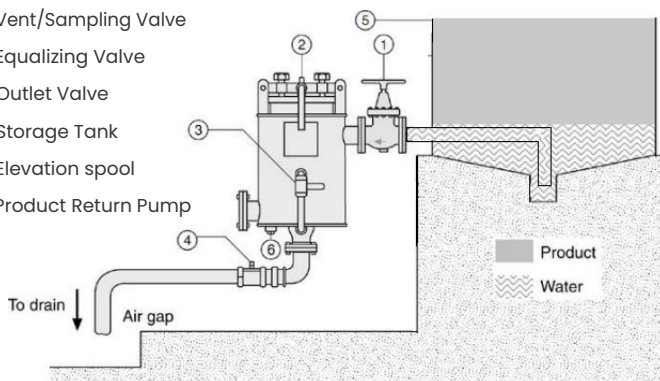

Fig 1: Installation at the lowest point of the tank

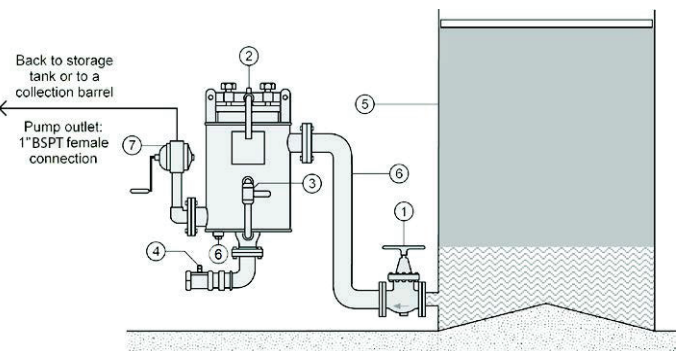

Fig 2: Installation including Manual Pump with elevation spool

Engineering Specifications

The Automatic Draining Valve is made of a fusion bonded epoxy coated carbon steel body and includes an integral stainless-steel Strainer. The valve is equipped with a built-in device for the prevention of vortex development within the storage tank during draining.

Installation does not require any incursion or penetration of the storage tank. All external piping, fittings, bolting and all metallic internal parts are made of stainless steel. No additional parts are required for resetting. Removing the valve cover for inspection or maintenance can be made in situ and does not require removal of the valve from the pipeline. The Automatic Drain Valves are assembled and hydraulically tested by the factory certified to ISO 9001-2015



Technical Specifications

Part	Material
Valve Body and Cover	Epoxy Coated Carbon Steel
Internal Parts	Stainless Steel
Seals	FKM
Ball Valves	Stainless Steel
Bolts	Stainless Steel
Plugs	Stainless Steel
Coating	Epoxy Blue RAL 5017
*Inlet Connection Flange	4" ANSI #150 RF B16.5
Drain Connection	BSPT 2 "
Max. Working Pressure	2.5 bar / 36 psi
Approx. Weight	64 kg / 141 lb

*Other connections available – contact ECO-VALVES

Dimensions

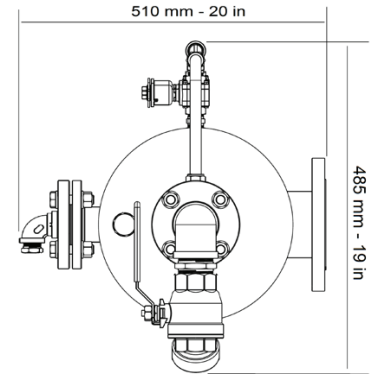

Bottom View

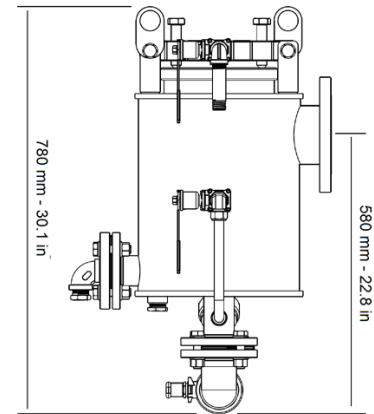

Side View

Flow Chart

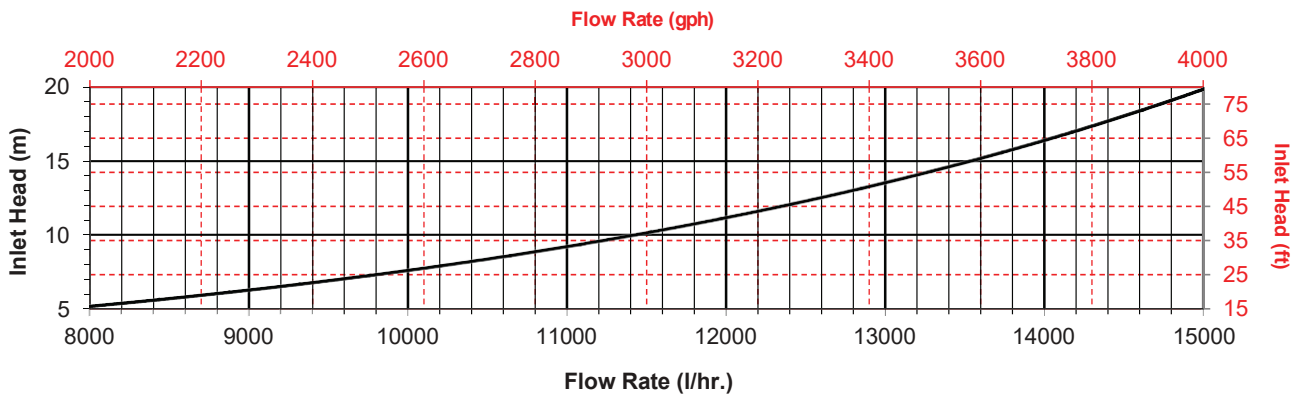

Ordering Code Designations

Type	Size	Connection	Options
TOO	4"	A5	P/PE/PP/VI/VE/BL
		ANSI#150 - A5	Manual Return Pump - P
			Electrically Return Pump - PE
			Pneumatic Return Pump - PP
			Oil/Water Visual Indicator - VI
			Oil/Water Electrical Indicator - VE
			Bottom Limit Switch Open/Close - BL

Product
Water

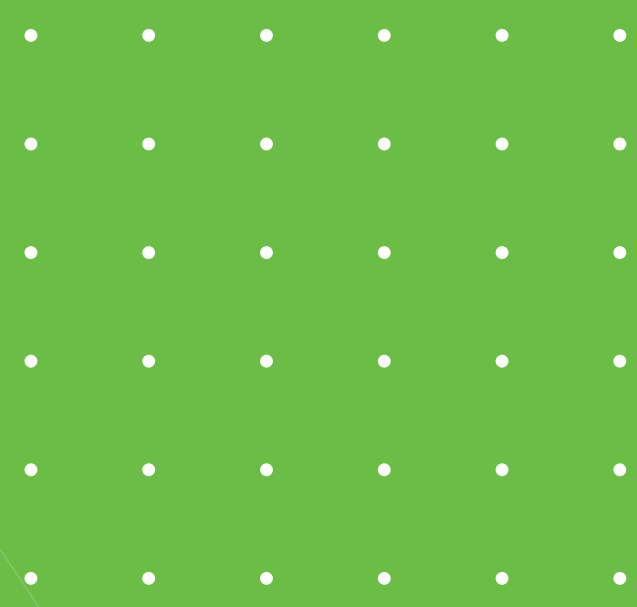

ECO-VALVES
Ecological Draining Solutions

30.10.2022